

# General Notes:

- 1) Material:
  - A) Plastic
- 2) Dimensional Tolerances
  - A) General:  $\pm 1/64$ "
  - B) Angular  $\pm 1^\circ$
- 3) All Units Inches / mm
- 4) Material Thickness .089" / 2.27mm

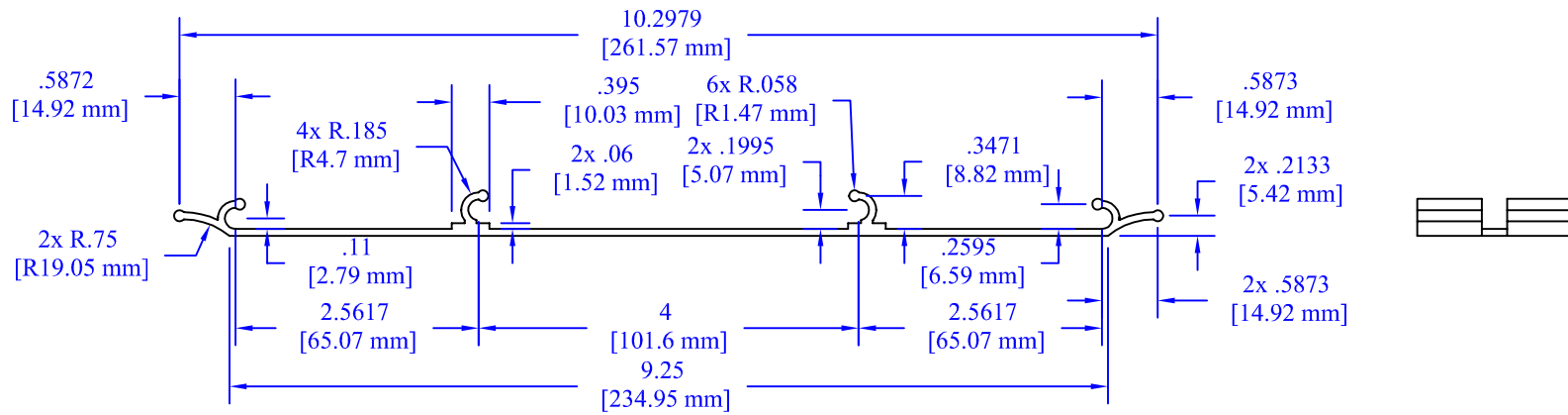
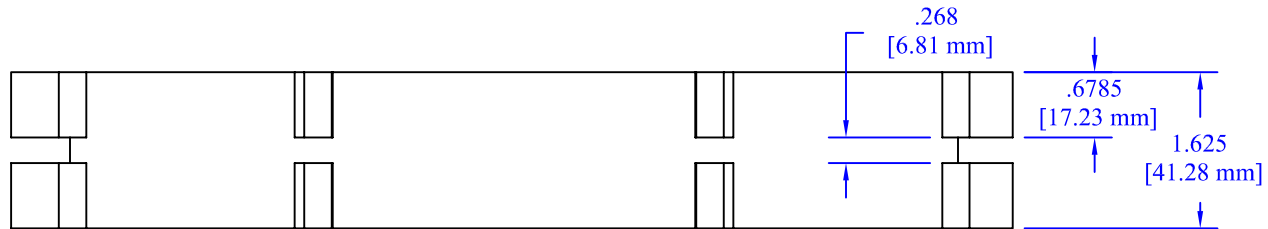
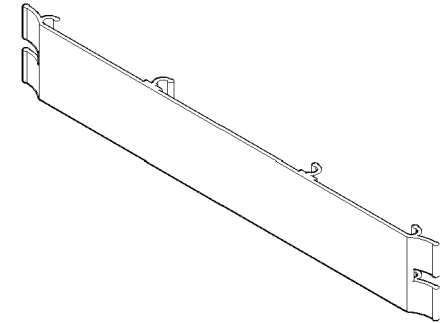

<b>WBT</b> LLC	This drawing in design and detail is the property of WBT, LLC. and must not be used except in connection with our work. All rights of design or invention are reserved.			
	PART # OR NAME			DRAWN BY
	<b>WBT Label Clip</b>			<b>RJM</b>
SIZE	DATE	SCALE	SHEET	REV
<b>A</b>	1/28/16	<b>6"=1'</b>	<b>1 OF 1</b>	<b>N/A</b>