

Flat Pattern Layout

General Notes:

- 1) Material:
Commercial Quality mill galvanized steel per ASTM A653 w/ G-90 coating. Min Yield = 33 KSI
- 2) Dimensional Tolerances:
A) General: $\pm .03"$
B) Angular: $\pm 2^\circ$
C) Hole location: $\pm 1/32"$
- 3) Material Thickness Min 14 GA = .080"
- 4) All Angles to be 90°U.N.O.
- 5) Finish: Electroplated After Fabrication

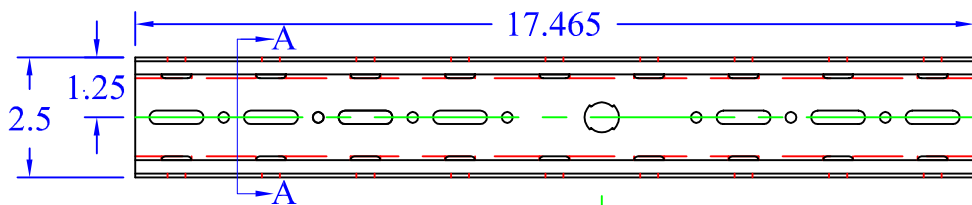

Formed Layout View

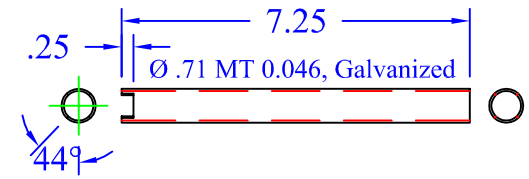

1a - PRESS PIPE

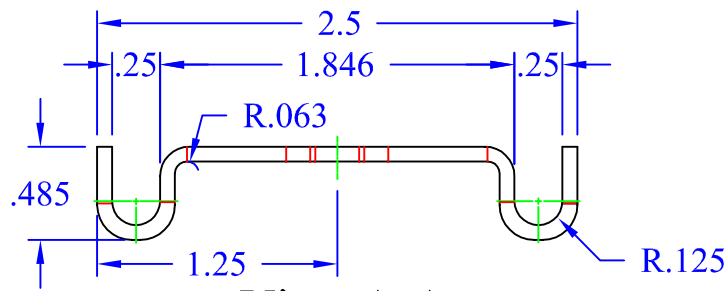

View A-A

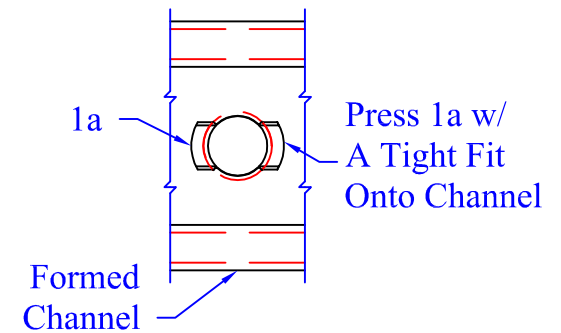

View B-B



This drawing in design and detail is the property of WBT, LLC. and must not be used except in connection with our work. All rights of design or invention are reserved.

PART # OR NAME		DRAWN BY	
NS CENTER SUPT 18		RJM	
SIZE	DATE	SCALE	SHEET
A	6/15/16	VARIES	1 OF 1
REV			N/A