

VIEW A-A
1:1 SCALE

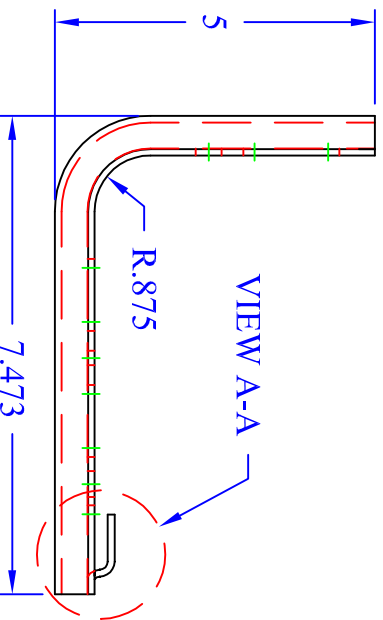

BENT VIEW

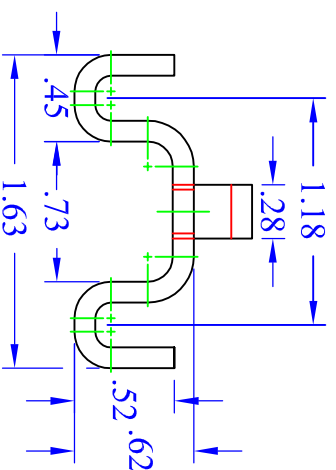

VIEW B-B
1:1 SCALE

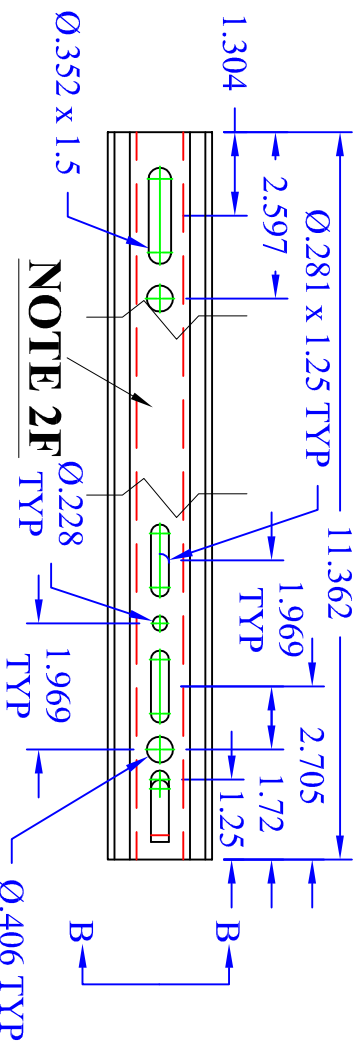

FLAT VIEW

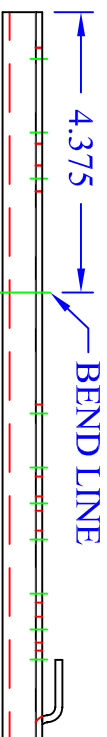

NOTE 2F
BEND LINE

General Notes:

- 1) Material:
 - A) Material to be commercial quality mill galvanized steel per ASTM A653 w/ G-90 coating . Min Yield = 33 KSI
 - B) Material to be commercial hot pickled & oiled steel per ASTM A569
- 2) Dimensional Tolerances:
 - A) General: .XX = ± .03" .XXX = .01"
 - B) Hole location: ± .03"
 - C) Hole diameter: ± .03"
 - D) Angular: ± 2°
 - E) Material thickness: ± .01"
 - F) Dimension for width in this area may vary between 1.625" and 1.657"
- 3) Material Thickness Min 12 GA = .1084"
- 4) All Angles to be 90° U.N.O.
- 5) Finish:
 - A) PreGalvanized G90 per ASTM A641
 - B) Powder Coat per ASTM D3451
 - C) Electroplated Zinc per ASTM B633

This drawing in design and detail is the property of WBT, LLC. and must not be used except in connection with our work. All rights of design or invention are reserved.

PART # OR NAME

L BRKT 6

DRAWN BY

RJM

SIZE	DATE	SCALE	SHEET	REV
A	6/8/15	4"=1'	1 OF 1	N/A

